

ROKSAN

XERXES

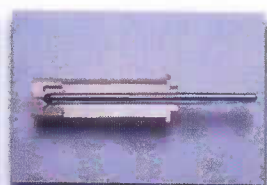
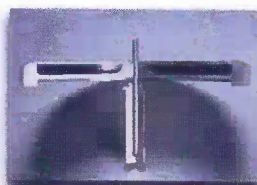

ANALOGUE

User manual
NEW & PRELIMINARY

ROKSAN AUDIO LIMITED 6 NORTHFIELD INDUSTRIAL ESTATE
BERESFORD AVENUE ALPERTON MIDDLESEX HA0 1NW ENGLAND
TEL. +44 (0)208 900 6801/ +44 (0)208 900 6802 FAX. +44 (0)208 900 0734
www.roksan.co.uk email info@roksan.co.uk

Congratulations on your acquisition of the original and classic ROKSAN **Xerxes** Record Player. This record Player was designed and manufactured to the highest specification and rigorously tested which has offered 2 decades of trouble-free pleasure and still remains one of the best record players in the world.

Your Xerxes is at the heart of your record playing system and the link between the tone arm/cartridge and the record. Its correct installation, set-up and operation will have a profound influence on the sonic performance of the entire record playing system.

Please read the contents of this manual thoroughly. It will help you to understand your Xerxes better and enhance your musical experience.

This manual is divided into the following sections:

- Introduction
- Caution
- Design
- Setup Summary
- Setup Diagrams
- Installation
- Operation
- Troubleshooting
- Guarantee
- Specifications
- Notes

UNPACKING

Included in the **NEW** packing of your Xerxes Record Player you will find:

- One Xerxes Inner Platter
- One Xerxes Outer Platter
- One Xerxes Drive Belt
- One Xerxes Spindle Cap
- One Vial of Xerxes.20 oil + Cotton Bud & lint free tissue
- One pair of cotton gloves
- One Xerxes Dust Cover
- 2.5mm A/F Allen Key
- One information pack

After removing these items please retain **all** packing materials. Correct packing is necessary for future transportation of your Xerxes Record Player.

(Please note the above applies to a new packaging obtained from ROKSAN for the original Xerxes)

MAINTENANCE

After switching the amplifier off and placing the stylus guard on, the record player may be cleaned with a lightly dampened soft cloth or a soft brush.

Avoid using abrasives or solvents.

***** Take care not to damage the cartridge stylus or the tone arm.**

- The Main Bearing requires recharging with oil every 12-18 months. **SEE BELOW**
- The Drive belt requires cleaning with a wax based furniture polish every 12-18 months. **SEE BELOW**

The Xerxes Record Player incorporates many unique design features and manufacturing techniques. It is important to observe the following to avoid any damage and to ensure optimum performance.

IMPORTANT

DO NOT attempt to run the record player without Main Bearing Oil
Careful when placing the Inner Platter
Careful when placing the Outer Platter onto the Inner Platter (Outer Platter should not hit the Motor Pulley or drop onto the Inner Platter)

The Structure

Xerxes has Two separate plinths used for decoupling across a selective frequency band.

1. The bottom plinth is 'grounded' to the supporting surface via three hard plastic feet. This plinth houses the motor assembly and the three two stage adjustable top plinth decouplers ('BLOB' assembly).
2. The top plinth features the familiar cut-out of the Xerxes where the Main Bearing/Platter assembly and the Tone arm/Cartridge are supported without touching it and supports the middle plinth.
3. The middle plinth supports the precision motor assembly and is connected & isolated from the bottom plinth via a set of three decouplers.

The top, middle and the bottom plinth are designed and manufactured from MDF and finished in a high gloss piano lacquer to provide the required rigidity/mass/damping for the tonearm/platter assembly.

The motor is free to pivot on its own bearing on an axis of rotation coincident with the shaft of the motor. With this unique dynamic system transient speed changes are absorbed and do not affect the measuring platform.

The Bearing / Platter Assembly

At the heart of Xerxes is Roksan's unique and formidable self centring, self aligning true single point main bearing. The innovative design of this bearing provides almost silent, frictionless rotation, precisely defining the rotational axis. The bearing sleeve is gun-drilled from solid phosphor bronze and honed to provide spindle/bearing sleeve gap of 2/10,000" along its length! The only contact is between the polished spindle tip and the captive super precision hardened steel ball.

The spindle is made from hardened steel and is ground with a taper that locates into the inner platter without the use of adhesive or the need for pressing.

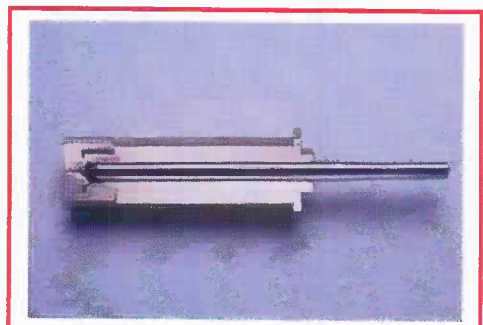
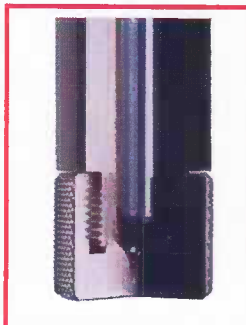
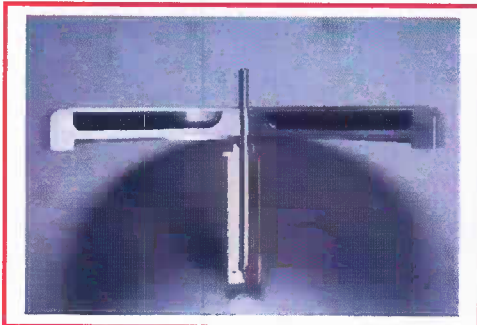

The inner and outer platters are both machined from solid aluminium alloy instead of normal castings to ensure the material is homogeneous. Each complete platter is constructed of two parts that are 'friction' fitted together. Each part is designed as a tuning fork and hence it's free from any nonlinearity. Their natural frequencies are linearly damped, as these two parts are joined together by friction only. The platters are machined to extremely high tolerances to ensure roundness and balance. Required inertia for a smooth and constant angular speed is achieved through high peripheral distribution of mass. This maximizes inertia to mass ratio and reduces undue pressure on the bearing contact point. It is this level of attention to detail throughout the design that ensures musical integrity.

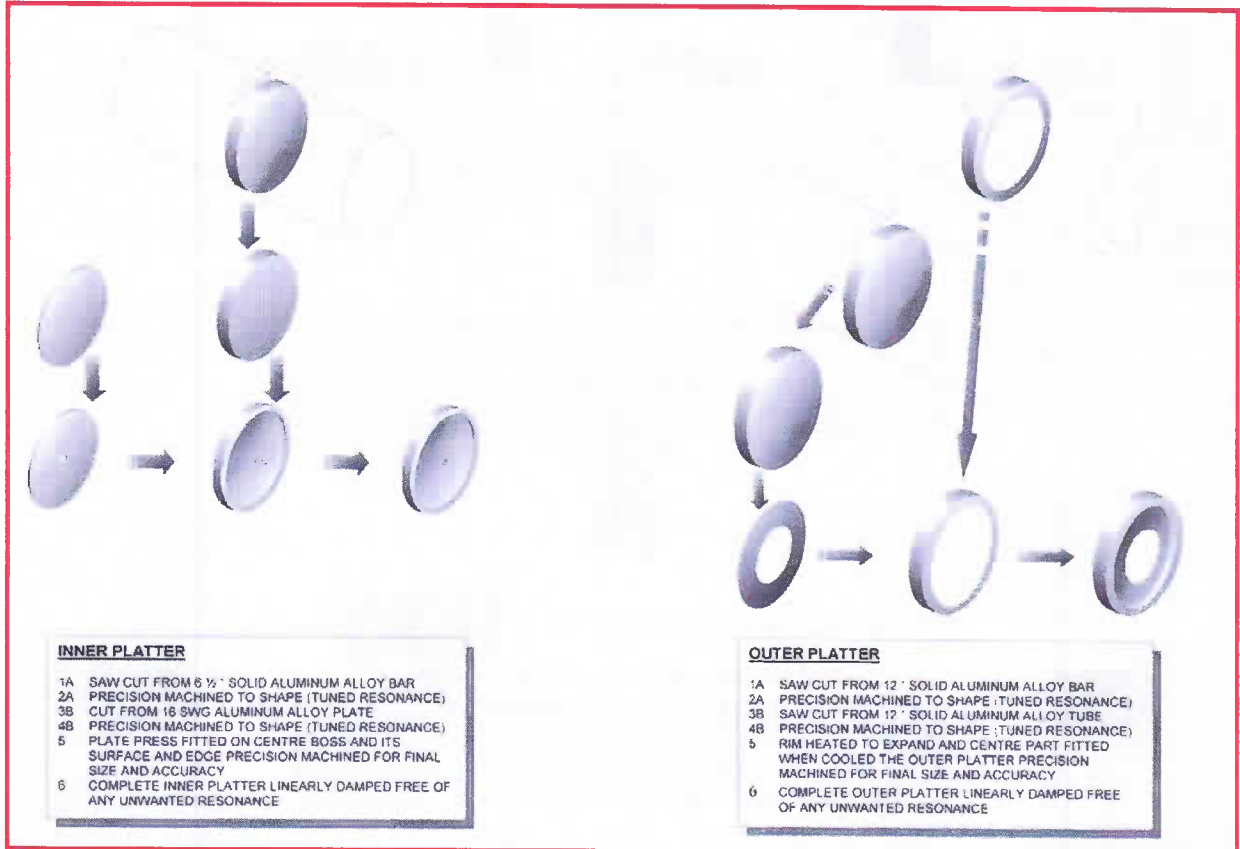

ANALOGUE

Placing the Xerxes

Prepare a level surface, using a spirit level, on which to place the **Xerxes** ('absolute' level is not critical as long as the surface is reasonably level). If you wish to use a dedicated equipment support, ensure that you get a 'vertically' rigid table. For best results it should sit rigid and level on a solid floor. For the wall mounted turntable support, ensure the same.

NOTE: For best results use the **Xerxes Upgrade Plinth**

Removing the Motor Transit Protective Foams

The Foam Block and the Side Protection foams prevent the precision motor and its bearing mount assembly from being damaged in transit. Remove the Foam Block; gently place your finger on the Motor Pulley to avoid vertically moving the motor and remove the Side Protection foams. Now the motor is in its operating condition and free to swivel back and forth while restrained by the spring. Please keep all the motor packing foams safe in the packaging for future use.

Preparing the Main Bearing

Remove the rubber plug on the main bearing. Push a cotton Q-tip down to the bottom of the housing and rotate it while gently pressing down. Keep turning as you pull it out. The cotton bud should now have a recess in its tip, which shows that the precision ball bearing is correctly positioned at the bottom of the housing (See figure). From the small vial of oil, pour 4 to 5 drops of oil into the bearing housing. Always replace the plug, to keep the bearing housing clean, if you are not fitting the inner platter immediately.

IMPORTANT: Always use ROKSAN supplied Main Bearing Oil

Placing the Inner Platter

Remove the inner platter/spindle assembly from the accessories tray. The spindle is slightly oiled to protect the tool steel spindle (remember to do the same if you are storing your Xerxes for a length of time).

Wipe the oil from the spindle using a soft lint-free tissue.

Remove the plug from the bearing and carefully guide the spindle into the main bearing hole. Gently spin the inner platter. The platter will slowly sink over a period of about ten to twenty minutes. Do not force the platter down. The spindle is factory fitted to ensure that the inner platter runs true. Take extra care not to knock or bend the spindle.

You can check that the inner platter has settled by gently raising and lowering the spindle by about 3mm. You should hear a quiet metallic click as it touches the ball bearing. If there is enough oil a ridge will be visible at the top of the bearing housing.

If you do not see a ridge, use one more drop of oil.

Fitting the Belt

The belt should be wiped with a **non-alcohol**, wax based polish (i.e. aerosol type such as Pledge) before fitting. When this has been done, the belt can then be fitted around the inner platter and motor pulley. Turn the inner platter by hand for a few revolutions and the belt will come to rest in its correct operation position.

Fitting the Tonearm

You will need to follow the tonearm manufacturer's instructions as most tonearms differ slightly in their methods of fixing.

Connecting the Arm Cable

Use a standard type arm cable preferably the ROKSAN 5-pin Din High Definition Tonearm Cable. This must either be 'freely' dressed in between the foam strips or fixed securely to the bottom plinth using cable ties (See below). It is important that the arm cable is 'loose/free' between the arm and plinth (While in between the foam strips or secured with cable-ties). Otherwise this will restrict the movement of the Top plinth/arm-board and interfere with the decoupling/isolation of the **Xerxes**.

Fitting the outer platter

Remove the outer platter from its plastic bag. Gently place the outer platter on the inner platter; the recess on the underside locates onto the plate of the inner platter. Take care not to hit the motor pulley with the rim of the outer platter.

Fitting the Mat

It is best to use the new Roksan **R_{MAT-5}** with your **Xerxes** to provide optimum contact between the record and the platter assembly. It fits over the main bearing spindle in the centre and rests uniformly over the platter surface.

The Centre Piece (Spindle Cap)

Roksan introduced this unique removable centre piece with the original Xerxes. Slide the centre piece over the bearing spindle to assist placing the record centrally on the mat. Before playing the record, the centre piece can be removed to eliminate any direct mechanical contact between the record and the main bearing spindle. The only contact would be through the mat and the stylus. It is important to note that

IMPORTANT: Use of any clamp directly connects the vinyl to the structure and allows unwanted 'noise' to be immediately present in the vinyl and thus picked up by the stylus.

Do not use any record weights as this may permanently damage the Main Bering.

Connecting the Power Supply

The dedicated turntable power supply is connected to the rear of the turntable using the **4 pin** connector. *Always connect the power supplies before switching them on.*

Operation

Switch on the dedicated **Xerxes Power Supply** and choose the desired speed. The platter should start turning. Place the record on the mat ensuring the centre piece is in place. When the record is on the platter remove the centre piece and place it either on the top plinth or a safe place *e.g. on the supporting rack.*

Fitting the Inner Platter

- 1 Pull out the Main Bearing Plug and place it in the Oil Vial bag
- 2 Carefully clean the Main Bearing with one of the Cotton Buds and check that there is a ball impression on the tip
- 3 Remove the oil vial cap and charge the Main Bearing with 4 to 5 drops of Roksan supplied Oil
- 4 Using the Lint Free Tissue gently clean the Inner Platter Spindle free from any dirt. (Wear cotton gloves when handling the Platters)
- 5 Gently place the Inner Platter Spindle into the Main Bearing and allow it to settle down *

* Due to very tight tolerances the Inner Platter will take some time to settle down

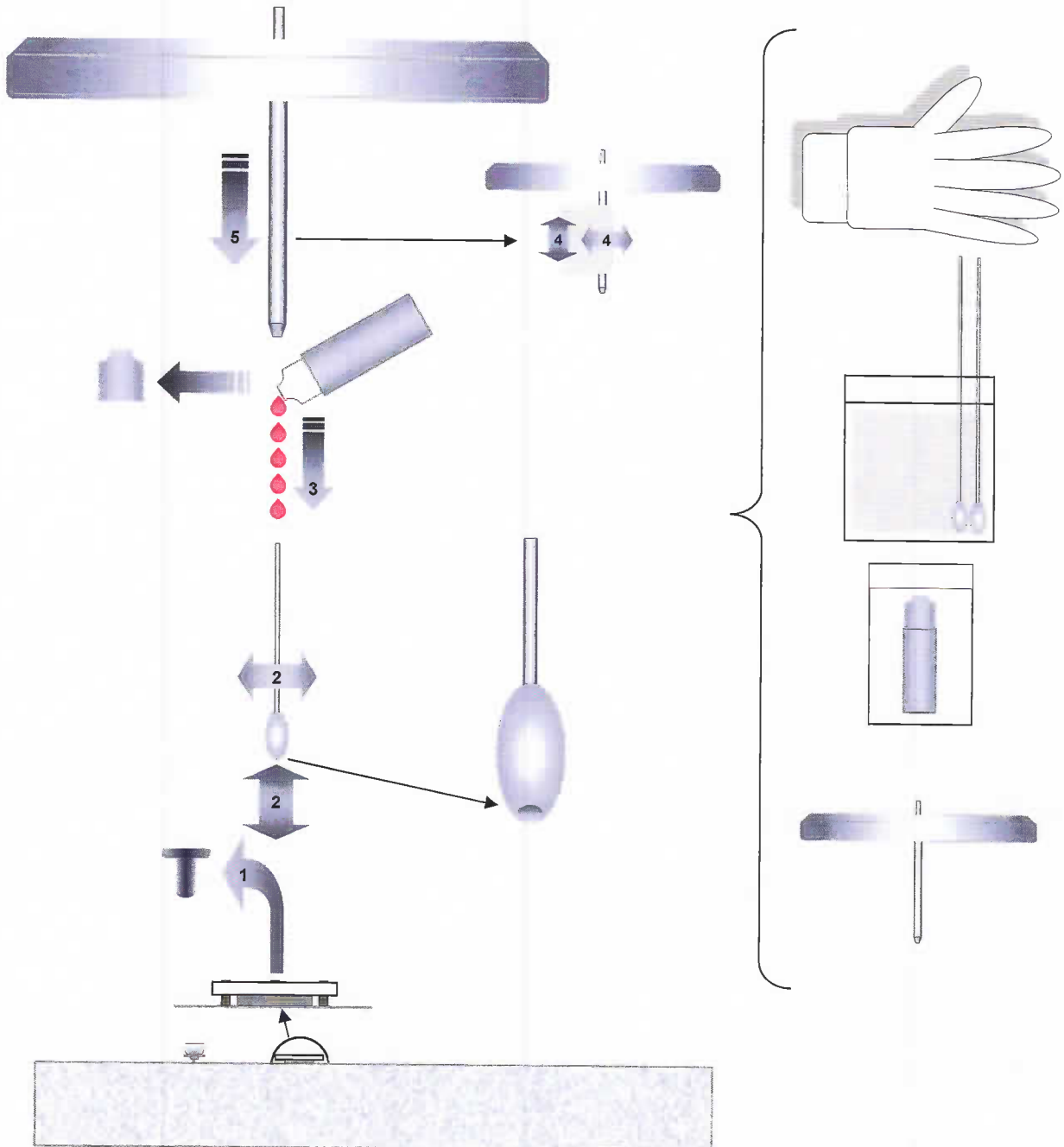

NOTE:
It is better to fit the outer Platter & Tonearm/counter weight before checking and adjusting levels.

There is a difference (approx. 2mm) between the 'outer' part and the 'cut-out' part of the top plinth as shown by the ↓.

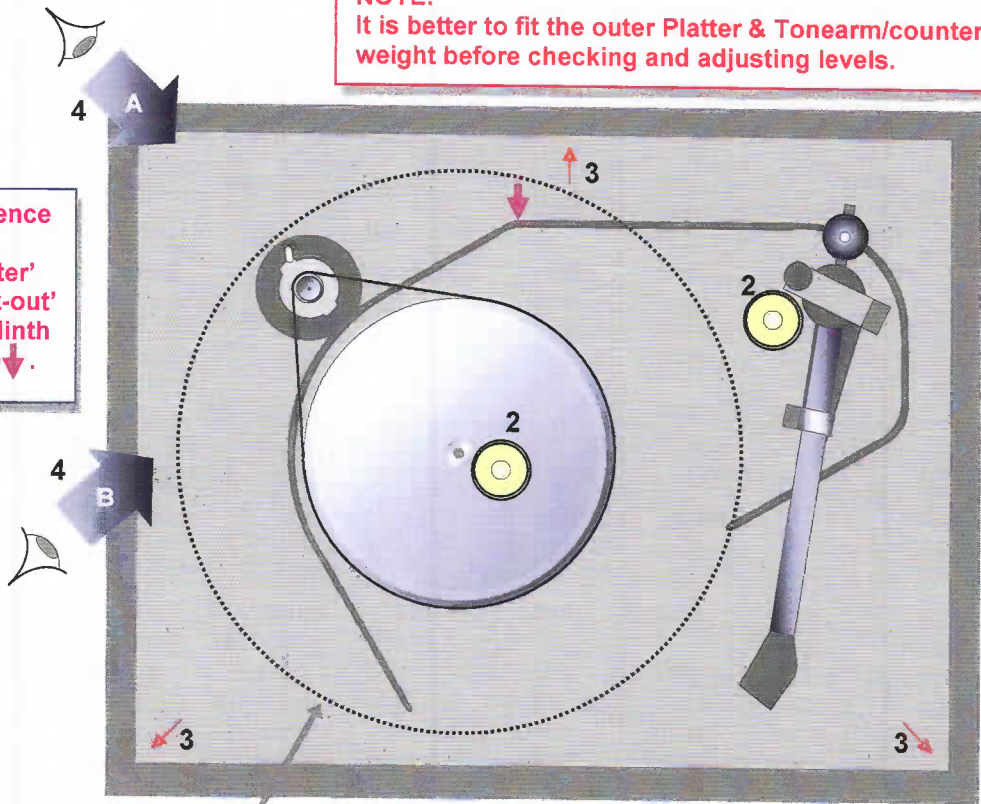

- Level Adjustments**
- 1 Carefully place the outer platter 'upside down' on the inner platter (This will allow you to observe the motor/pulley/belt etc.).
 - 2 Carefully adjust the Main bearing screws until the inner platter is level with the 'cut-out' part of the Top Plinth (see below). To assist use a light spirit level and check the levels as shown above.
 - 3 Carefully adjust the three 'BLOBs' until there is minimum gap between the Top Plinth and the Surround. (NOTE: early Xerxes models require a small flat blade screw driver where as the later models require a 2.5mm A/F Allen Key to adjust the 'BLOBs')
 - 4 Carefully adjust the motor bearing fixing screws to level the motor pulley with the inner platter (see below).

3 → :
Aim for minimum gap between the Top plinth & the Surround without them touching each other.
Note the Top plinth should be free to move left to right and back to front.

Motor Pulley & Inner/outer platter alignment

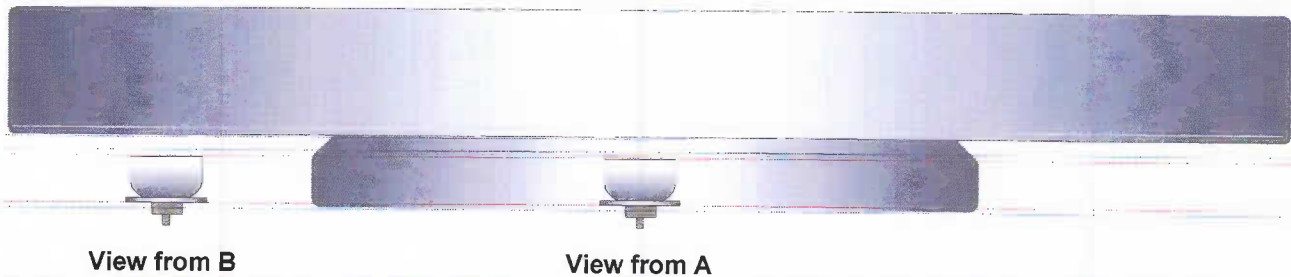

View from B
Roksan Audio Ltd

View from A

Xerxes Record Player User Manual
© Roksan Ltd
Version 2.0
ENGLISH

NOTE:

IF the Outer platter is too close or touching the Top plinth at the back; fit a 1 (or 2mm) Xerxes Shim to the Main Bearing Housing. This will raise the Outer platter clear from the top plinth. Please note afterwards the tone arm should also be raised to correct the VTA.

There is a difference (approx. 2mm) between the 'outer' part and the 'cut-out' part of the top plinth as shown

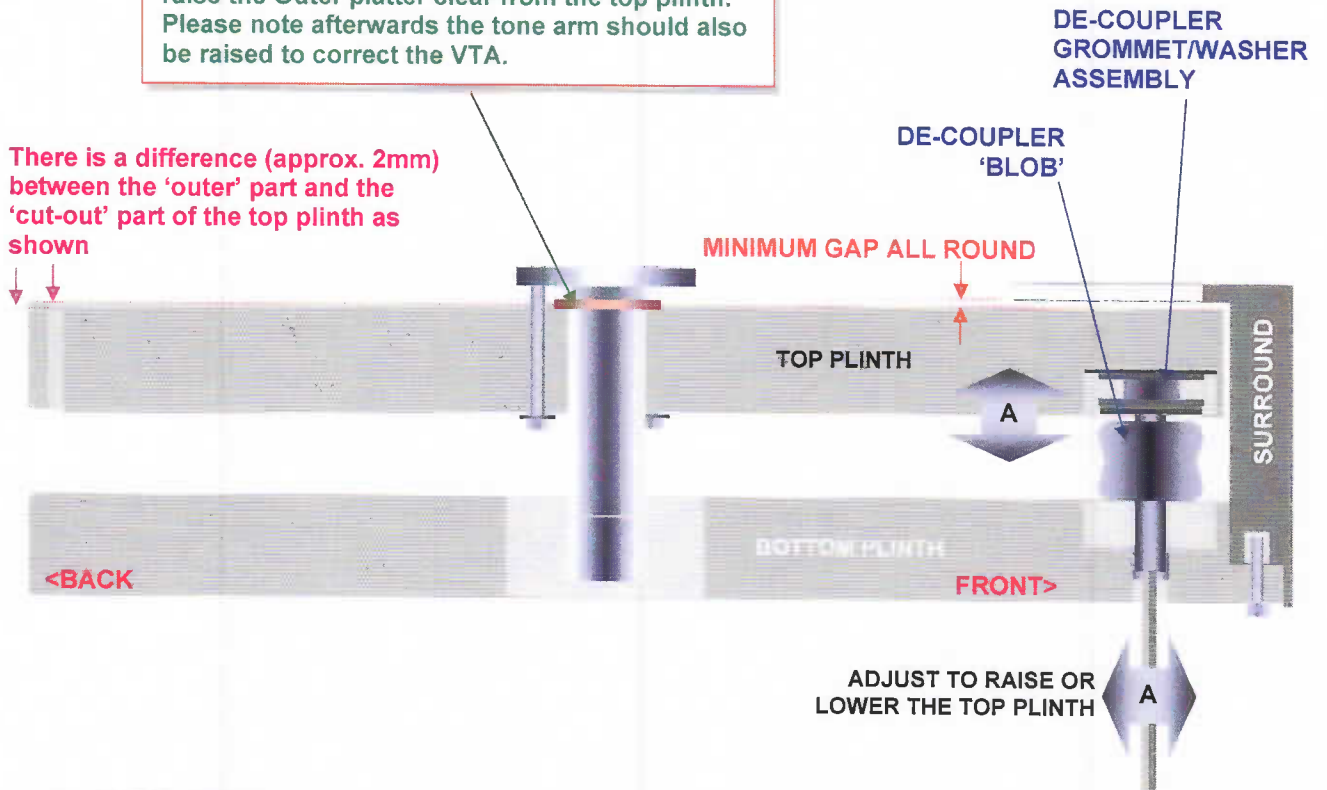

Top Plinth 'height' Adjustment

- Gently place the Surround on the Bottom Plinth (check it is seated fully down)
- Adjust the 'BLOBS' for minimum gap between the Top Plinth and the Surround (as shown above)

NOTE:

Use a 2.5mm A/F Allen key or a small flat blade screw driver as necessary.

FOR EARLY XERXES USE A SMALL FLAT BLADE SCREW DRIVER

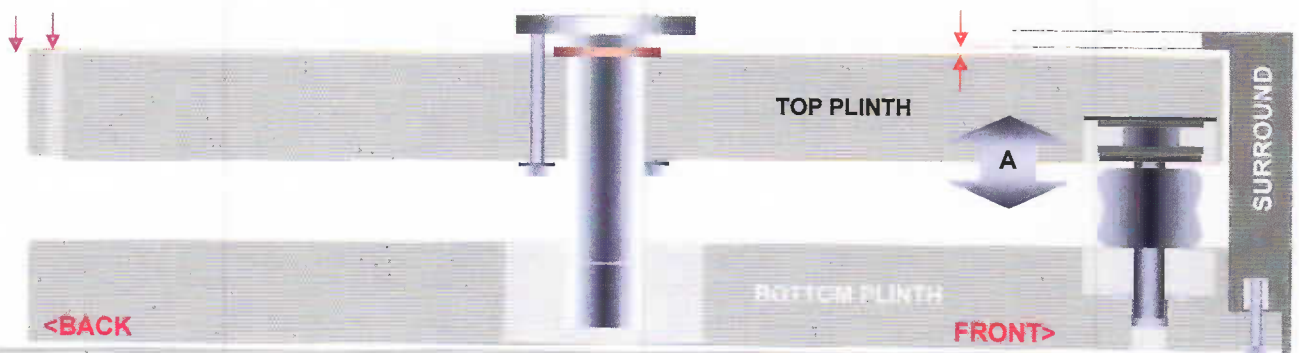

The Inner Platter should be aligned level with the 'cut-out' part of the Top Plinth (near the tonearm mounting hole). Carefully place the outer platter the right way up on the inner platter and observe the gap between the under side of the outer platter and the top surface of the Top Plinth. First look from the front of the record player and then from the side. Adjustment to the platter alignment is achieved through the Main Bearing fixing screws. There are 3 fixing screws and tightening/slackening these will tilt the axis of the main bearing and hence the platter level.

Platter level adjustment relative to the arm mounting area ensures correct azimuth between the platter/record and tonearm head-shell.

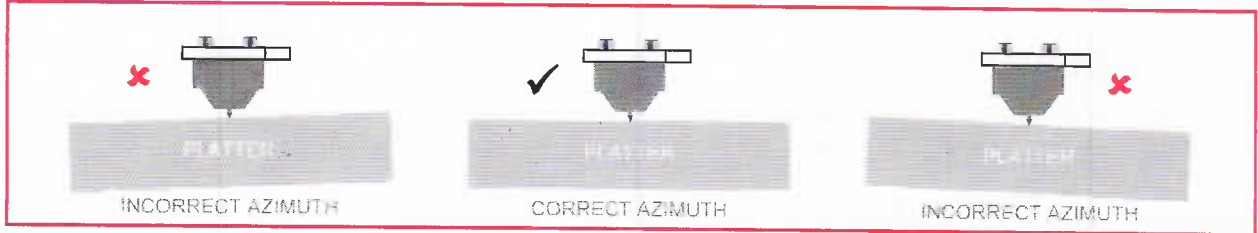

First adjust the LEFT to RIGHT and then the FRONT to BACK. See below:

PLEASE NOTE THE FIXING BOLT HEADS ARE NOT VISIBLE FROM THE SIDE GAP

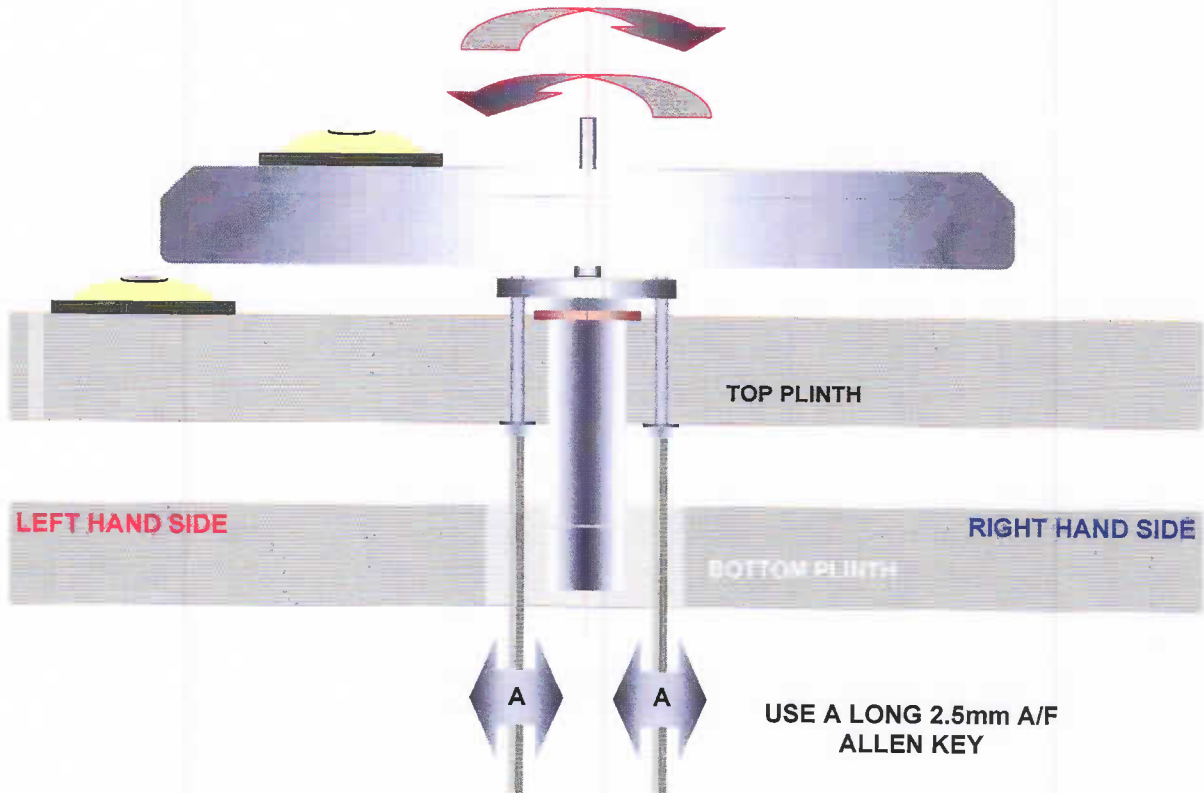

Use a long 2.5mm A/F Allen Key to adjust the Main Bearing Fixing Screws. Looking from the front adjusting the front two screws will tilt the platter assembly LEFT to RIGHT as shown above. DO NOT over tighten or slacken the fixing screws too much. Correct tension is to have the screws tightened by 1-1.5 turn after they have come into contact with the plinth. So when adjusting, slacken one a little and tighten the other a little. Adjustment of

these two screws will also change the FRONT to BACK level. So you need to check the front to back level after adjusting the left to right level. See below:

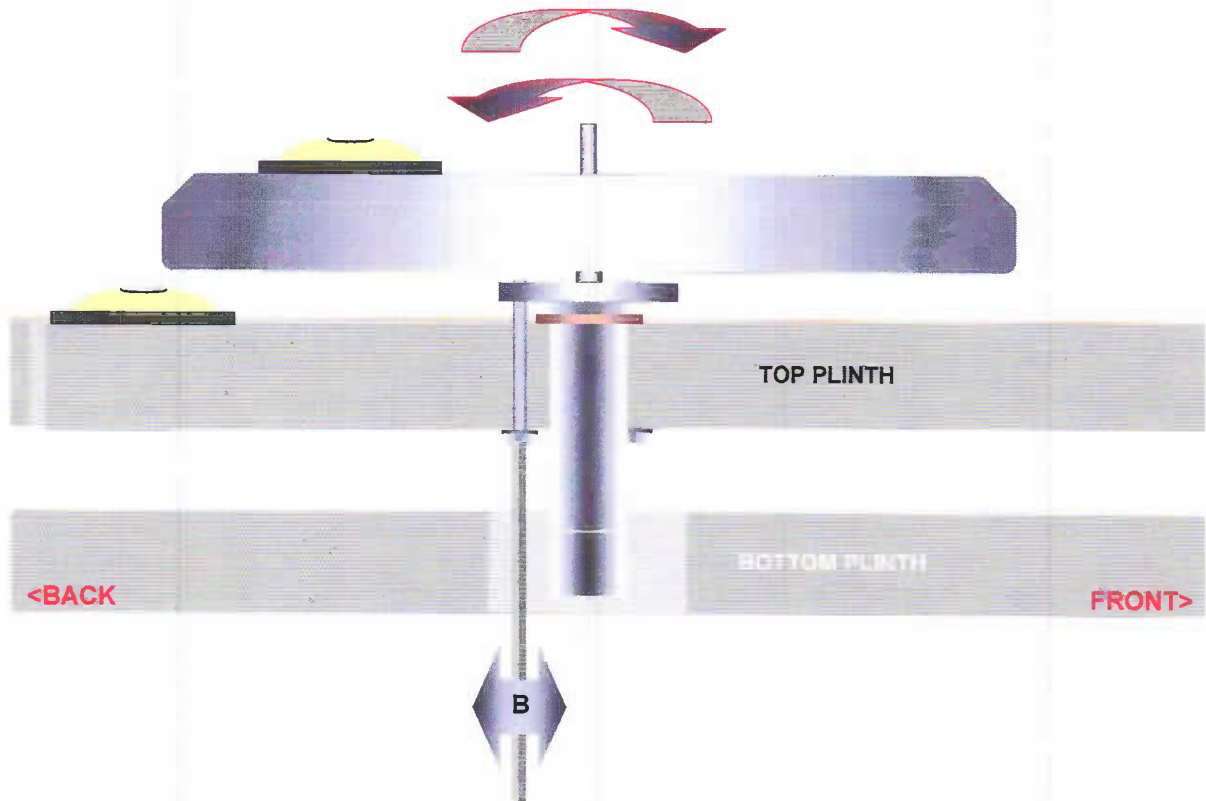

Use the 2.5mm A/F Allen Key and looking from the left hand side, adjust the back (3rd) screw to tilt the platter assembly FRONT to BACK as shown above. DO NOT over tighten or slacken the fixing screw too much. Adjustment of this screw will NOT change the LEFT to RIGHT level.

Belt riding position

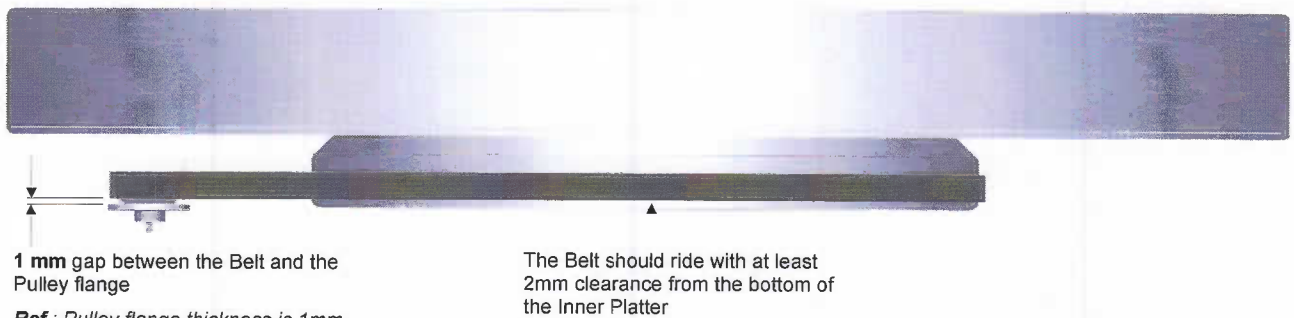

1 mm gap between the Belt and the Pulley flange
Ref.: Pulley flange thickness is 1mm

The Belt should ride with at least 2mm clearance from the bottom of the Inner Platter

NOTE:

- With the belt riding higher on the pulley (i.e. more than 1mm gap), the rotational speed would be very slightly increased.
- With the belt riding lower on the pulley (i.e. less than 1mm gap), the rotational speed would be very slightly decreased.

Drive Belt Set-up and Maintenance

- If the levels are adjusted but the drive belt rides a little too high, then remove the belt and gently stretch it. Wait a couple of minutes and refit the drive belt and the outer platter and check the running position again (Repeat this process if necessary)

Motor Pulley & Inner/outer platter alignment

View from A

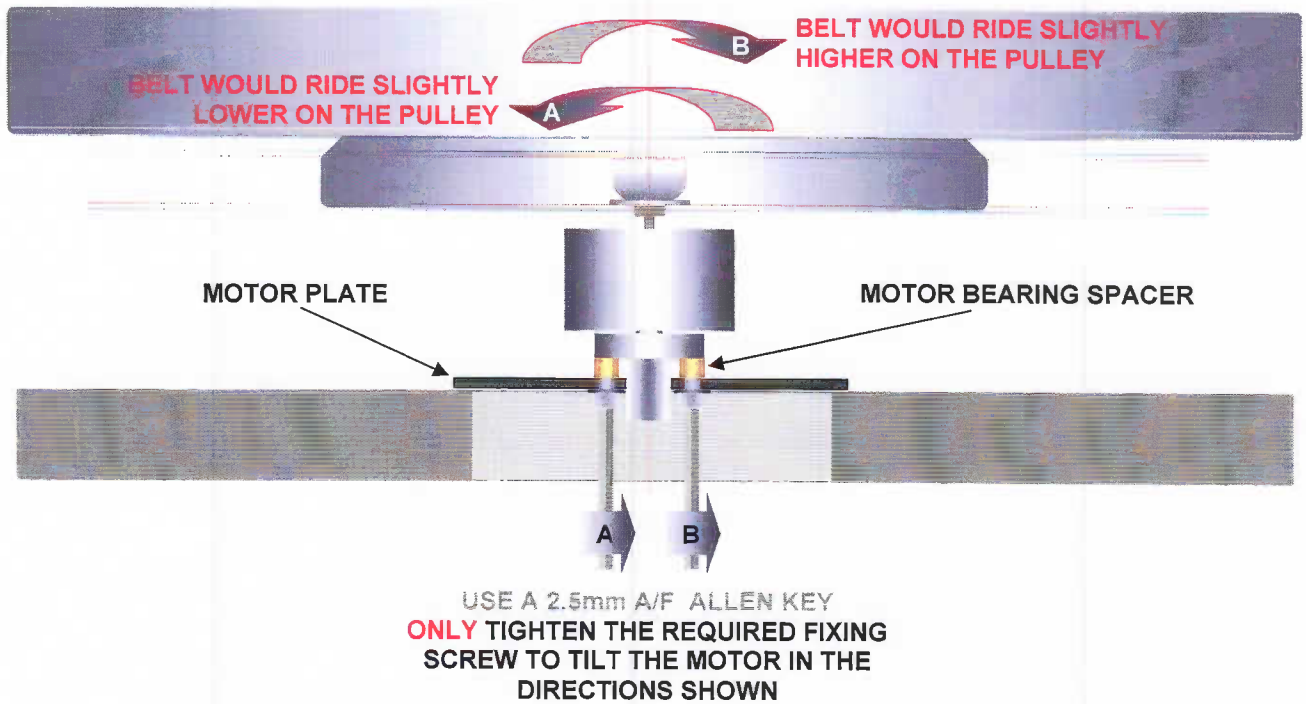

View from B

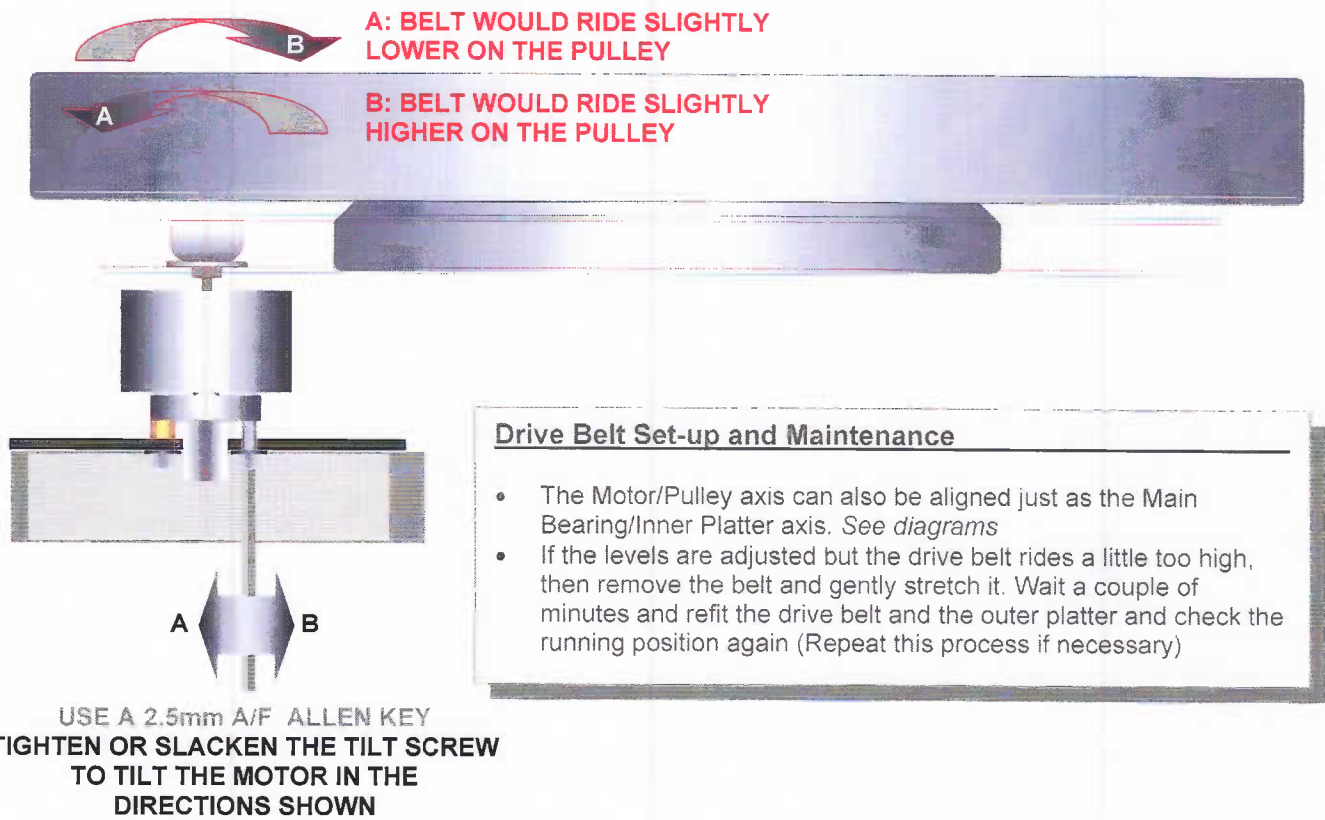

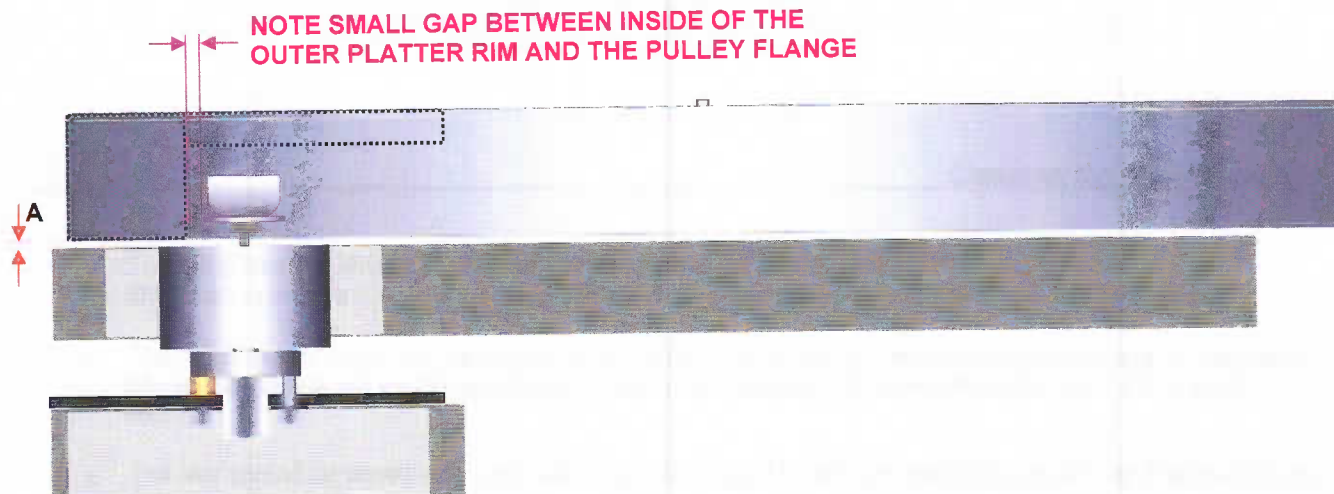

Motor Body and Pulley clearance form the Outer Platter

- When the Motor & Platter alignment, Top Plinth & Motor position are correct; there will be sufficient clearance between the Motor body and the under side of the Platter rim (A) and between the Motor Pulley flange and the inside of the Platter rim (B). See *diagram*
- If the Platter is touching the Motor body or Pulley, then re-check the positions, levels and alignments of the Motor assembly, Top Plinth and the Platters.

Motor Spring Adjustment

- The Motor Spring acts against the Belt Tension to allow the Motor Body to move freely about its own axis. See *diagram*
- If the tension in the spring is too low, then adjust the screw to lower the spring clip. This increases the tension in the spring.
- If the tension in the spring is too high, then adjust the screw to raise the spring clip. This decreases the tension in the spring.

To check for correct tension:

- Fit, the belt and place the outer platter upside down on the inner platter.
- Switch unit to 33 rpm.
- Gently touch the rim of the outer platter to slow it down a fraction and observe the motor body.
- When the tensions in the spring and the belt are equal and opposite, the motor body will freely move back and forth several times before it comes to rest.

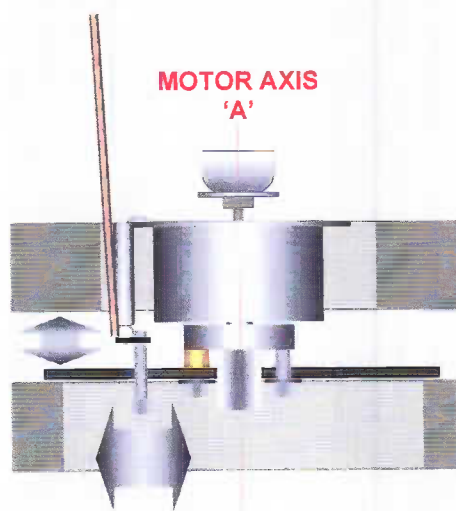

MOTOR FREE TO
ROTATE ABOUT
'A'